

Technical Information

Taper Ground Joint Dimensions

W-LG's taper-ground joints are manufactured according to ASTM E 676 specifications. Final grindings for diameter and tapertolerances are fractional as compared to those permitted by Commercial Standard CS-21 of the former National Bureau of Standards. Ts is the symbol used to designate interchangeable taper-ground joints, stoppers, and stopcocks. All mating components are finished to a 1:10 taper.

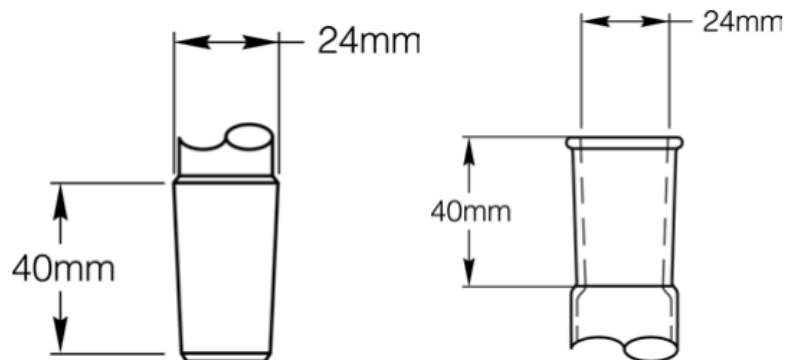

Standard Dimensions for Full Length Interchangeable Taper-Ground Joint Dimensions

Joint Size Designation	Approximate Diameter at Small End (mm)	Approximate Length of Ground Zone (mm)	Diameter at Large End of Ground Zone (mm)
7/25	5	25	7.5
10/30	7	30	10
12/30	9.5	30	12.5
14/35	11	35	14.5
19/38	15	38	18.8
24/40	20	40	25
29/42	25	42	29.2
34/45	30	45	34.5
40/50	35	50	40
45/50	40	50	45
50/50	45	50	50
55/50	50	50	55
60/50	55	50	60
71/60	65	60	71
103/60	97	60	103